



Lifting Eye TAPG/TAPG-S

Product information

The eyes can be loaded with working load limit in all directions. All the eyes are pivoted to avoid breakage in the eyes, which also make it possible to fold it aside when it is not used.

Model TAPG: Lifting D-Ring and Bridge - without Screws.

Model TAPG-S: Lifting D-ring, bridge and 2 screws 8.8 EN 24014 (DIN 931)

Attachment-point, bolt-on type, in working
load limits of 3 - 8 t.

Features:

- Compact design
- Secured four times against breakage
- Working range 120°
- Bolt on plate also serves as marking stencil

The D-link must be able to move freely. The load take-up may not be supported on edges or on the sling point.

Material: Eye of alloy steel.

Marking: WLL.

Note: The surface that the lifting eyes shall be attached to shall be flat and tolerate the load it is going to be exposed to.

Warning: Only screws with a minimum strength class of 8.8 EN 24014 (DIN 931) may be used

Safety factor: 4:1

Part Code	Code	WLL ton	Thread mm	Torque Nm	a mm	b mm	c mm	Ø d mm	e mm	f mm	g mm	h mm	l mm	Weight kg	Delivery time
42150380503200	TAPG 3	3.15	M20	210	12	56	50	18	34	130	90	21	51	1.08	7
42150380505200	TAPG 5	5.3	M24	290	15	67	60	22	42	160	110	25	63	2.04	7
42150380508200	TAPG 8	8	M27	550	20	80	70	26	55	190	130	28	67	3.58	7

Technical data

WLL (ton)

<input type="text"/>	<input type="text"/>	<input type="text"/>	<input type="text"/>
3.15	4.75	4.25	
5.3	8	7.1	
8	12	11.2	

Blueprint

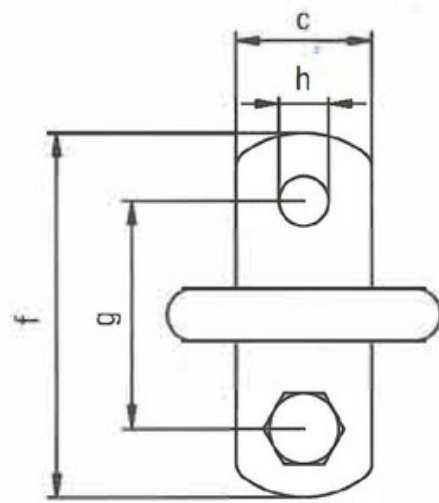
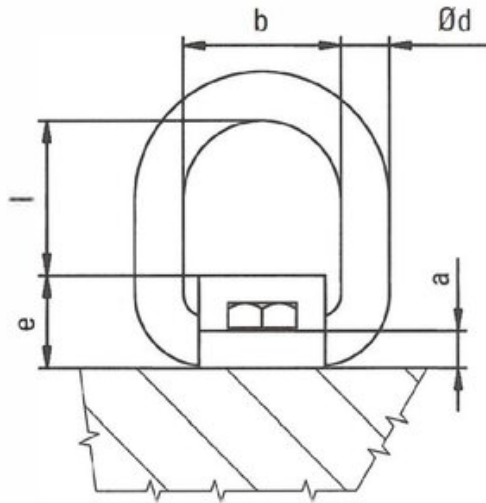

Anschlagart
 kind of attachment

Stück / number of pieces
 Neigungswinkel
 inclination angle

Bezeichnung Code	Nominal W.L. mm W.L.	0°		0°-45°		45°-60°		Schraube nutriv	Anschluß- moment tightening torque
		Working load limit W.L.	Working load limit W.L.	Working load limit W.L.	Working load limit W.L.	Working load limit W.L.	Working load limit W.L.		
FAPG- β	3.15	4.75	9.5	4.25	3.15	6.7	4.75	M20	210
FAPG- β	5.5	8	16	7.5	5.5	11.2	8	M24	290
FAPG- α	8	12	24	11.2	8	17	13.8	M27	350

Anschlagart
 kind of attachment

Stück / number of pieces
 Neigungswinkel
 inclination angle

Anschlagart
 kind of attachment

Stück / number of pieces
 Neigungswinkel
 inclination angle